



SAIL BOAT



SPORT FISHING



MOTOR BOAT

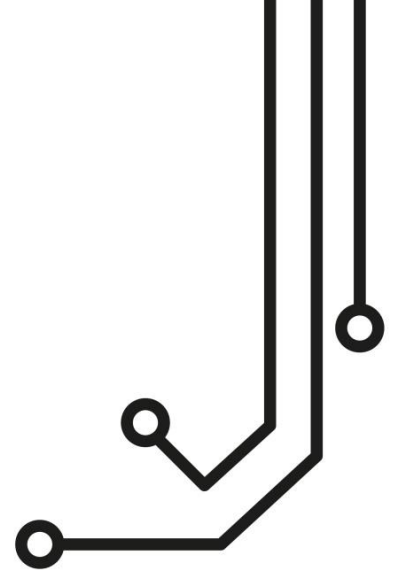

# **GPS160 POSITIONING SENSOR**

Installation and instruction Manual



## 1. Introduction

Congratulations on the purchase of your TriNav™ GPS160 Global Navigation Satellite System (GNSS) Positioning Sensor. It is recommended that this product is installed by a professional installer. You will need to purchase a suitable 1" x 14 TPI thread mounting bracket for the GPS160.

To coincide with the imminent "Full Operational Capability" (FOC) of the European Galileo system, Digital Yacht's release of their TriNav™ GPS160 smart positioning sensor will provide boat owners with a single sensor that will automatically read satellite data from the GPS, GLONASS and GALILEO constellations, choosing the best signals from over 80 satellites.

Wherever you are in the world you now have three times the number satellites to choose from, resulting in the GPS160 receiver having much better coverage, time to first fix and positional accuracy. Add to this the new high sensitivity receiver design, selectable baud rate and up to 18Hz position update rate and you have a GNSS receiver that is significantly better than every previous marine GPS receiver on the market.

The performance of this new TriNav™ technology is particularly noticeable when the sensor is mounted below deck/inside the wheelhouse or when there are obstructions blocking the view of the sky, such as a wet sail shadowing the antenna or when sailing in rivers or close to cliffs.

On larger boats, it is now possible to have three completely separate position sources, by setting one GPS160 to GPS mode, a second to GLONASS mode and a third to Galileo mode – giving you triple redundancy with three independent positioning systems.

The GPS160 also supports SBAS (Satellite-Based Augmentation System) which is the generic name given to the differential signal transmitted by various local geo-stationary satellites. SBAS allows the GPS160 receiver to remove errors in the position due to environmental conditions and improves accuracy down to <1m. Using WAAS in the US and EGNOS in Europe the GPS160 will automatically switch to differential SBAS mode when available.

The GPS160 utilises the latest in GNSS technology, but is also designed to be as compatible as possible with the hundreds of thousands of older systems still providing reliable service, on boats around the world. Featuring dedicated "Legacy" modes that output older NMEA 0183 V2.30 data and reduce the update rates, number of decimal places and satellite status information, the GPS160 can be configured to work with the newest and oldest systems on the market.

** Before operating the unit you should also familiarise yourself again with the user manual of the equipment that you are connecting the GPS160 to. Pay particular attention to the GPS Interfacing section and any settings that need to be configured for correct operation.**

## 2. Before you start

Carefully consider how you wish to connect the GPS160 to your existing navigation system before you start installing cables. The GPS160 has an NMEA0183 interface (10m cable), which can be connected directly in to many systems, but Digital Yacht also produce the following optional accessories for connecting the GPS160 data to other systems:

- WLN10 or WLN30 Wireless NMEA Servers for connecting to wireless mobile devices (phones/tablets/laptops)
- iKonvert ISO NMEA2000 Gateway for connecting to the latest NMEA2000 networks
- ST-NMEA Converter for connecting to older SeaTalk 1 systems from Autohelm/Raytheon/Raymarine
- NMEA to USB adaptor cable for connecting to PCs, a GPS160USB is available but for longer cable runs use the standard GPS160 and one of these adaptor cables.

For more information on these products and other Digital Yacht products please visit <https://digitalyacht.co.uk>



## 3. Installation

Before starting installation select a suitable location for the GPS160 Receiver. The unit is water proof and designed for on-deck mounting. The GPS160 antenna has the popular 1" x 14 TPI thread mount, found in many VHF antennas. A wide variety of different brackets are available for this type of threaded mount, consult your local marine electronics dealer or chandlery for more information.

The 1" x 14 TPI thread mount can also be removed by unscrewing the three hex bolts with a suitable Allen Key, allowing the GPS160 to be flush mounted on a flat horizontal surface. A mounting kit (as shown in the diagram below) is available from Digital Yacht (Part# X500.400). In this situation, a bead of silicone sealant should be applied around the antenna, after mounting it, to avoid standing water accumulating under the antenna.

### Dimensions;

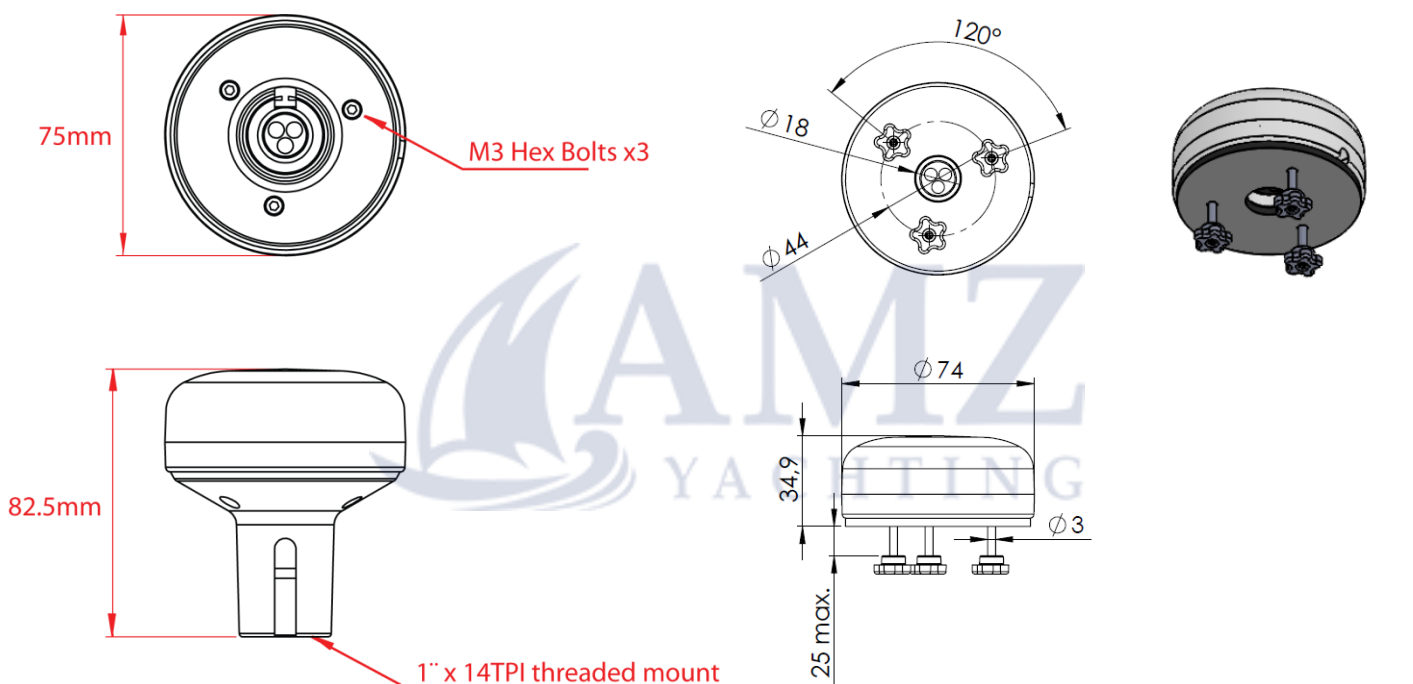

The GPS160 is supplied with 10m of cable and this should be routed through the vessel to a suitable dry internal location where it can be connected to the boat's DC power system and the equipment it will be interfaced with. The cable can be shortened, lengthened or joined without problems.

The GPS160 should be connected to the boat's DC supply via a 1 Amp fuse. The unit requires 9.6V to 28.8V supply voltage.

The GPS160 has a number of operating modes that can be set by adjusting four DIP switches inside the unit. Section 4 of this manual explains how to select the different modes. By default the GPS160 will output;

- **GLL, GGA, RMC, VLW, VTG and ZDA once per second at 4800 baud (TriNav™ Mode)**

This default mode is good for most applications and uses all of the available satellites from the GPS, GLONASS and GALILEO constellations.

On the next page, are the wiring details for the GPS160 and a series of connection diagrams that shows how to interface to other navigational equipment.



## GPS160 Power/Data Cable – wire colours;

Colour	Primary Function	Alternative Function
Red	Power + (12v or 24v)	
Black	Power – (0v)	
Yellow	NMEA Out +	
Green	NMEA Out –	
White	MOB Switch	NMEA IN+
Blue	NMEA IN-	1PPS Output

When connecting to a two wire NMEA Input (such as Raymarine), connect the GPS160 Yellow wire to the NMEA + Input and the Green wire to the NMEA – Input.

EQUIPMENT WITH TWO WIRE NMEA 0183 INPUT

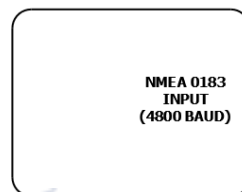

Boat's DC Supply

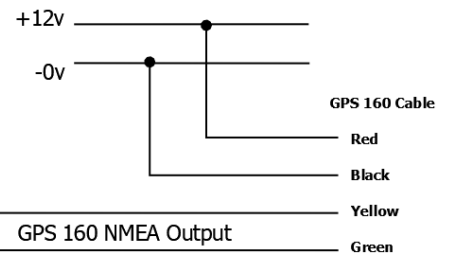

When connecting to a single wire NMEA Input (such as a Garmin), connect the GPS160 Yellow wire to the NMEA + Input.

EQUIPMENT WITH ONE WIRE NMEA 0183 INPUT

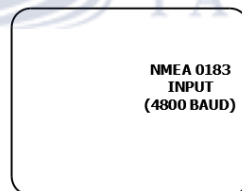

Boat's DC Supply

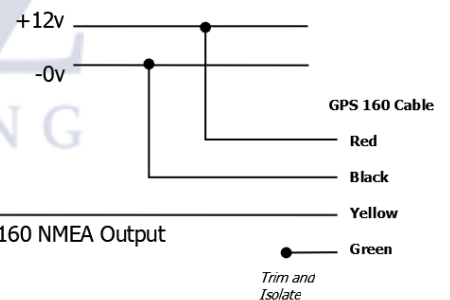

The Green wire is not used and along with all other unused wires, should have its exposed conductor removed and be terminated in a safe way so that it cannot short to any other wires.

The GPS160USB model is available for connection to a Windows/Mac/LINUX computer, but it is limited to the 5 meter USB cable length limitation. For larger boats, the 10m extendable cable of the standard GPS160 makes installation easier and then you can connect it to a computer, using a Digital Yacht NMEA to USB Adaptor, as shown below.

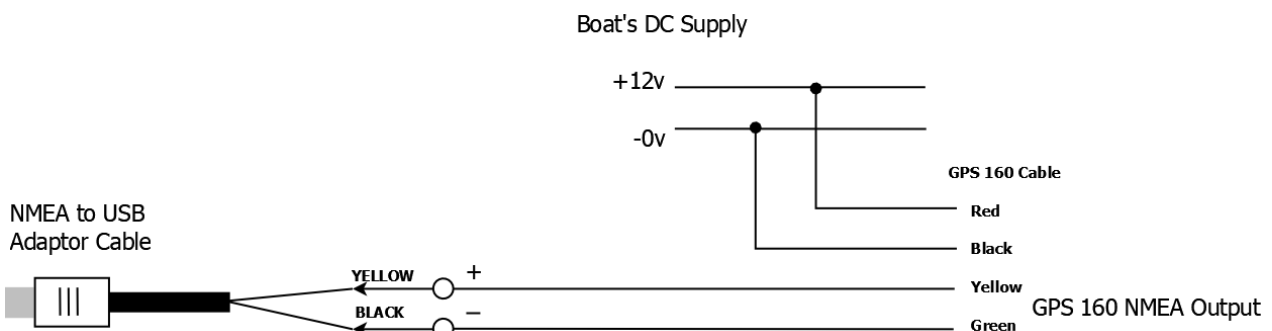



The GPS160 can also be used wirelessly to send GPS data to an iPad/iPhone or Android device by using one of Digital Yacht's WLN10SM Wireless NMEA Servers. The GPS160 should be connected to the WLN10SM as shown in the diagram below.

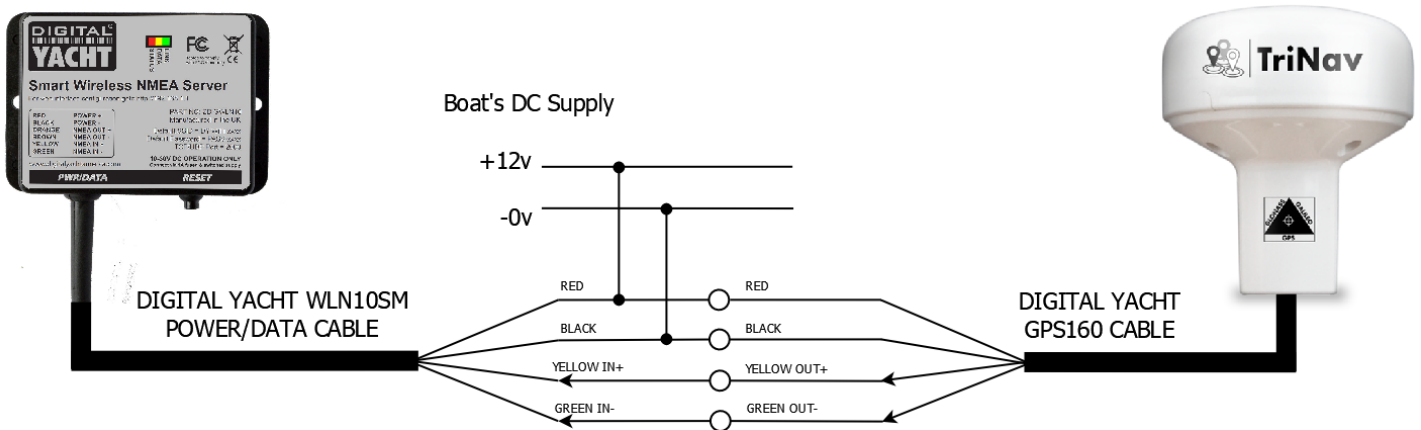

Many of our GPS sensors are sold to replace failed Raymarine GPS sensors Raystar 112, 120 and 125, which used the proprietary Raymarine SeaTalk™ interface. In most situations, you can find a spare NMEA 0183 input in the Raymarine system, to connect our GPS160 to, but if the only option is to connect it via SeaTalk™ then you can use a Digital Yacht ST-NMEA converter connected as follows.

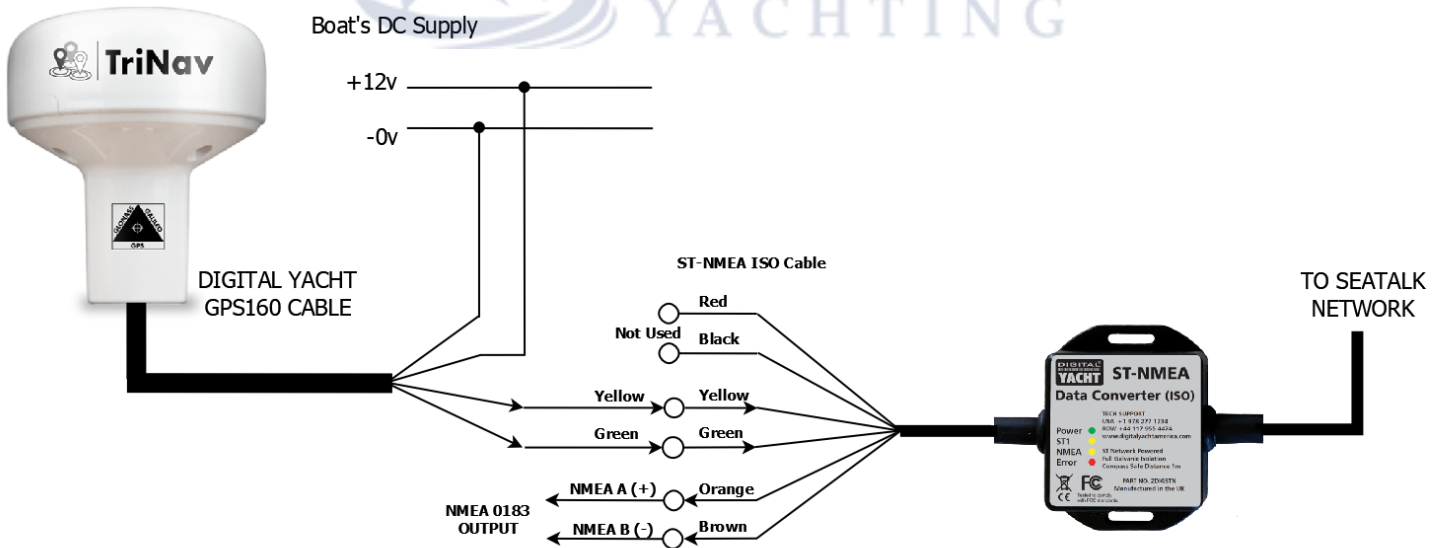

GPS160 to ST-NMEA CONVERTER

Most of the major marine electronics manufacturers now produce NMEA2000 GPS sensors but with the NMEA 2000's 6m length limitation on drop cables, plus the relatively large NMEA 2000 connectors that these cables have, installation of NMEA 2000 GPS sensors can be quite difficult.



Where longer cable runs are required or space to fit cables is tight, we recommend using our GPS160 with one of our popular iKonvert NMEA 0183 to NMEA 2000 gateways. The GPS160's slim 10m cable can be easily extended up to 45m and with no connector to worry about, can be easily run through existing conduits and tight spaces. Once you arrive at the NMEA 2000 network "backbone", simply wire the GPS160 to Digital Yacht's iKonvert ISO gateway (as shown below) and the GPS160 data will immediately be available on the NMEA 2000 network.

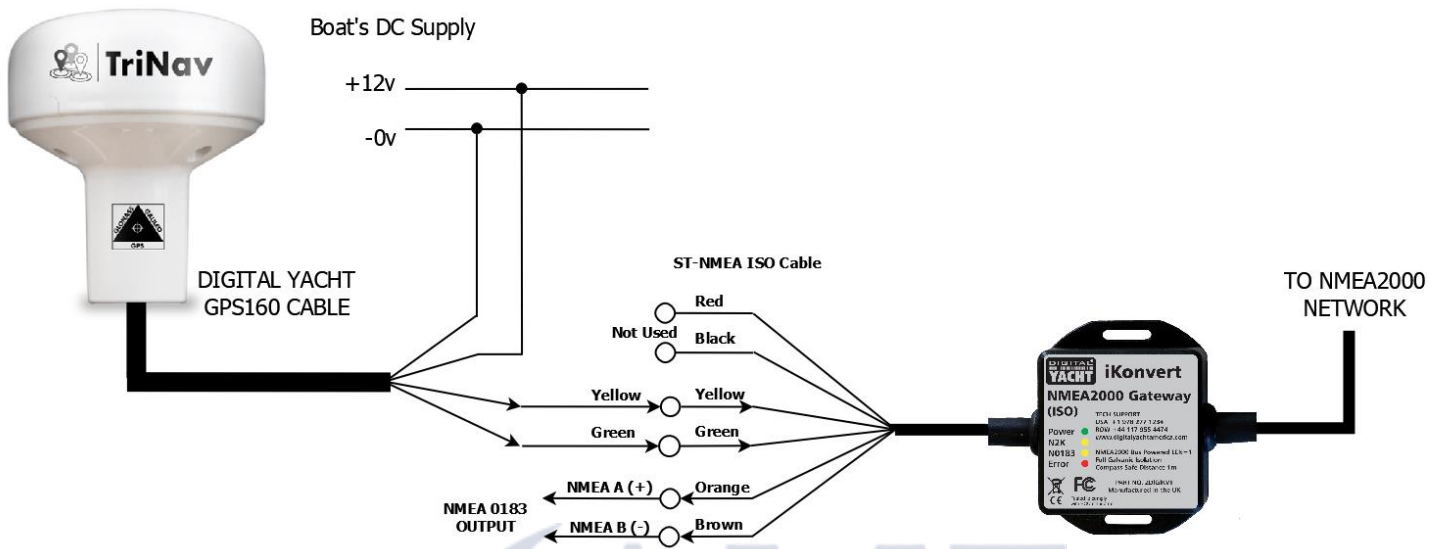

## Installing a Man Over Board Switch

The GPS160 has an additional new and innovative feature where you can fit a "Man Over Board" (MOB) push switch that can cause the GPS160 to create a "synthesised" AIS MOB message that most modern AIS enabled chart plotters will recognise and trigger an MOB alarm.

The GPS160 sends both a MSG1 and MSG14 AIS MOB (!AIVDM) sentence that includes the Lat/Lon at the time the button was pressed and an MMSI number = 972000000.

The push button should be wired to the GPS160 as follows and must be pressed for 3 seconds or more for the AIS MOB messages to be sent. The sentences are transmitted at whatever baud rate the GPS160 is set to and will continue to be sent every 60 seconds until the GPS160 is power cycled.

If used with an iKonvert, the AIS MOB messages are converted to NMEA 2000, but the iKonvert must be set to a mode which supports the VDM sentence. All of these modes are 38400 baud, so the GPS160 must also be set to 38400 baud.

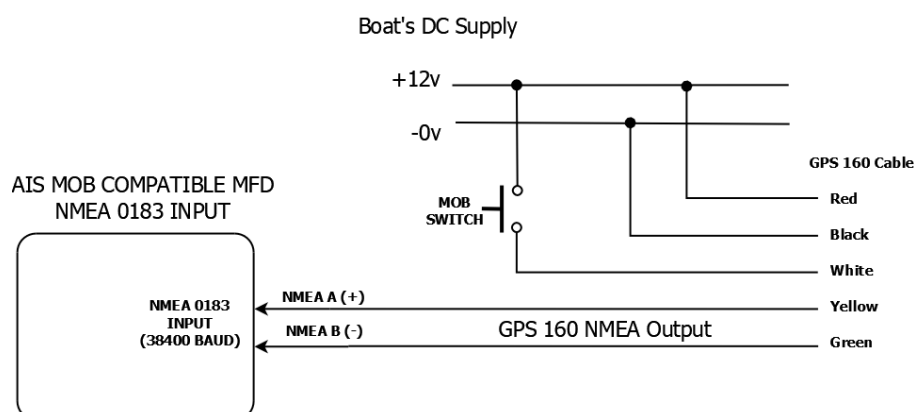



## 4. Mode Selection

The GPS160 can be operated in a number of different modes, designed to satisfy different installation scenarios and optimise performance with older systems.

By selecting different modes, you can change the baud rate, the NMEA 0183 sentences transmitted, the sentence update rate, satellites used for navigation and

- GPS at 4800 baud for legacy systems
- TriNav™ reception at 38400 baud for new plotters
- “Turbo Mode” at 115K baud for PC race software

Selection of the operating mode is via four “DIP” switches inside the unit. Changes to the switches will become active when the GPS160 is power cycled (turned off/on).

There is a green LED on the PCB that indicates if the GPS is working correctly and a red LED that illuminates if there is a fault. The photo of the PCB shows the location of the LEDs and switches.

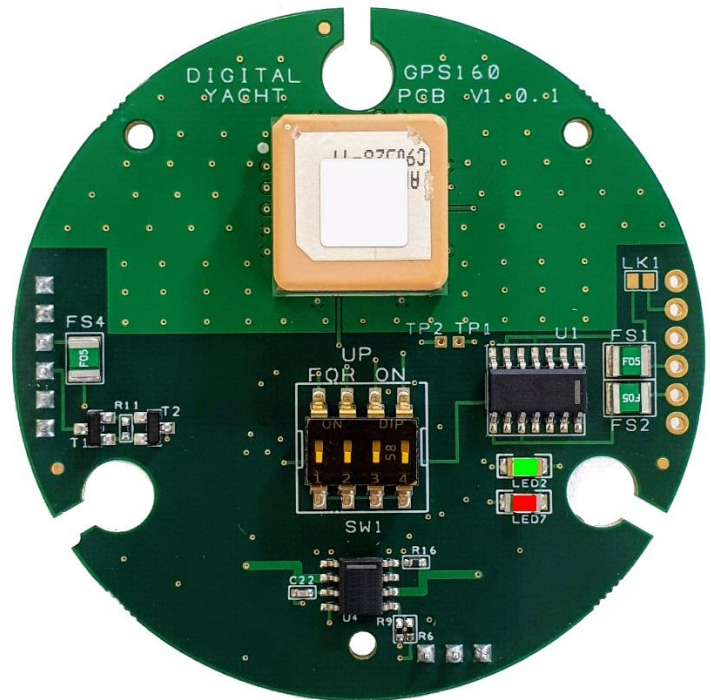

Within 2-3 seconds of applying power to the GPS160, the LED should illuminate as follows;

LED State	Description
Green LED ON	Configured correctly for 4800 baud
Green LED Slow Flash	Configured correctly for 38400 baud
Green LED Quick Flash	Configured correctly for 115K baud (Turbo Mode)
Red LED ON	Unused Mode Selected (check DIP switches)
Red LED briefly flashes	A Man Over Board sentence has been transmitted

To access the DIP switches, it is necessary to open the GPS160. It is recommended that this operation is only carried out by an approved Digital Yacht Dealer/Distributor, any physical damage to the PCB will not be covered by warranty.

Before opening the GPS160, turn off all DC power to the unit and then remove the threaded mount by unscrewing the 3xM3 hex bolts using a suitable Allen Key. Then using a Torx T6 screwdriver, remove the three screws that hold the GPS enclosure together. Gently pull the enclosure apart being careful not to lose the O-Ring seals (1 large outer and 3 small screw pillar O-Rings).

Once the GPS160 PCB is exposed, set the four switches to the relevant positions for the required operating mode as shown in the table on the next page.

**ⓘ To protect the switches during the surface mount production process, a yellow transparent film is placed over them. This should be carefully removed using tweezers before attempting to change them.**



## Operating Modes

SWITCHES	MODE	SATELLITES	BAUD	RATE	NMEA DATA	VER
	Tri-Nav Legacy Mode (default)	GPS+GLONASS+GALILEO	4800	1 HZ	GGA/GLL/RMC/VLW/VTG/ZDA	2.3
	Tri-Nav 6Hz Mode	GPS+GLONASS+GALILEO	4800	6 HZ	RMC	4.1
	Tri-Nav All Satellite Info 4800 Baud	GPS+GLONASS+GALILEO	4800	1 HZ	GSA**/GSV**/RMC/	4.1
	Tri-Nav All Sentences 1Hz	GPS+GLONASS+GALILEO	38400	1 HZ	DTM/GGA/GLL/GSA/GSV/RMC/VLW/VTG/ZDA	4.1
	Tri-Nav All Sentences 6Hz	GPS+GLONASS+GALILEO	38400	6 HZ	DTM*/GGA/GLL/GSA*/GSV*/RMC/VLW*/VTG/ZDA	4.1
	Tri-Nav Standard Sentences 10Hz	GPS+GLONASS+GALILEO	38400	10 Hz	DTM*/GGA/GLL/GSA*/GSV*/RMC/VLW*/VTG/ZDA	4.1
	GLONASS 1Hz All Sentences	GLONASS	4800	1 HZ	DTM/GGA/GLL/GSA**/GSV**/RMC/VLW/VTG/ZDA	4.1
	GPS 1Hz All Sentences	GPS	4800	1 HZ	DTM/GGA/GLL/GSA**/GSV**/RMC/VLW/VTG/ZDA	4.1
	GALILEO 1Hz All Sentences	GALILEO	4800	1 HZ	DTM/GGA/GLL/GSA**/GSV**/RMC/VLW/VTG/ZDA	4.1
	Tri-Nav "Professional" Mode 1Hz	GPS+GLONASS+GALILEO	38400	1 Hz	DTM/GBS/GNS/GRS/GSA/GST/GSV/RMC/VLW*/VTG/ZDA	4.1
	Tri-Nav "Professional" Mode 10Hz	GPS+GLONASS+GALILEO	38400	10 Hz	DTM*/GBS*/GNS/GRS*/GSA*/GST*/GSV*/RMC/VLW*/VTG/ZDA	4.1
	GPS Only Legacy mode	GPS	4800	1 HZ	GGA/GLL/GSA***/GSV***/RMC/VLW/VTG/ZDA	2.3
	Future Use					
	Future Use					
	Future Use					
	Full "Turbo" Mode	GPS+GLONASS+GALILEO	115000	18Hz	DTM*/GGA/GLL/GSA*/GSV*/RMC/VLW*/VTG/ZDA	4.1
	* These sentences output at 1HZ					
	** These sentences output every 4 secs					
	*** These sentences only include GPS satellites output every 4 secs					

After changing the DIP switches, it is necessary to power cycle the GPS160 (turn off/on) before the new operating mode becomes active. Check the Green LED to make sure that the expected baud rate is active and that the Red Error LED is not illuminated.

**NOTE** – If using the GPS160 on an NMEA2000 network with an iKonvert, we recommend setting the GPS160 to “TriNav Standard Sentences Mode” which is switch state 0101 and the iKonvert to “GPS HS Mode (10Hz)” which is switch state 0011. This combination will provide all of the information that a modern NMEA2000 network needs for a good GNSS position source.



## 5. Technical Specification

<b>Receiver</b>	72-channel U-Blox M8 engine GPS L1C/A, SBAS L1C/A, QZSS L1C/A, QZSS L1 SAIF, GLONASS L1OF, Galileo E1B/C
<b>Sensitivity</b>	-165 dBm typical
<b>Update Rate</b>	1Hz by default (configurable up to 18Hz)
<b>Accuracy Position</b>	<1m with SBAS and 3.0-5.0m without SBAS typically (67%)
<b>Accuracy Velocity</b>	0.05m/sec typically (50%)
<b>Time</b>	± 60ns
<b>Differential GPS</b>	SBAS (WAAS, EGNOS, MSAS, GAGAN and QZSS)
<b>Time to First Fix</b>	26sec (typical)
<b>Technology Supported</b>	GPS, GLONASS and GALILEO
<b>Maximum Altitude</b>	50,000m
<b>Maximum Velocity</b>	500m/s
<b>Operating Temperature</b>	-40°C to +85°C degrees Celsius
<b>Maximum Current</b>	30mA (@12Volts)
<b>Dimensions</b>	75mm diameter, 82.5mm high (with mount), 32mm high (no mount)
<b>Weight</b>	300g
<b>Protocols</b>	NMEA-0183 Version 2.3 or 4.1
<b>NMEA messages</b>	DTM, GBS, GNS, GRS, GSA, GST, GSV, RMC, VLW, VTG and ZDA
<b>Power Input</b>	VDC +9v to 34v
<b>Cable</b>	White 10m Shielded Cable (4.5mm OD)

